

MACT400 series

AIR UNITS (F.R.L.UNIT)



Specification



Symbol

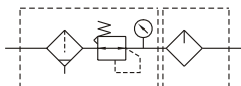

Model	MACT400		
Components	MAF400, MAR400, MAL400		
Bore No.	8A	10A	15A
Port size	1/4	3/8	1/2
Medium	Air		
Operating pressure range (※)	0.05~1 MPa		
Proof pressure	1.5 MPa		
Effective orifice	24mm ²	35mm ²	40mm ²
Regulated pressure range	0.05~0.85 MPa		
Ambient temperature	- 5~ + 60°C (No freezing)		
Filter element	Standard: 40 μm Option: 5 μm		
Lubricating oil capacity	200c.c		
Min. Flow for oil drip	50 ℓ/min	200 ℓ/min	400 ℓ/min
Recommended lubricating oil	Turbine oil ISO-VG32		
Attachment	Pressure gauge (PG-50), bracket		
Weight	2000 g		

Order example

MACT400 - 8A - D - □ - □

MODEL

BORE SIZE
8A: 1/4
10A: 3/8
15A: 1/2

D: Auto drain valve (FMRF300)
N: Nylon bowl

FILTER ELEMENT
Blank: 40 μm
5u: 5 μm

PORT THREAD
Blank: Rc thread
G: G thread
NPT: NPT thread

※1. Standard unit contains semi-auto-drain function when operating pressure below 0.05 MPa.

※2. Choose auto-drain FMRF300, the pressure range is 0.15 ~ 1 MPa.

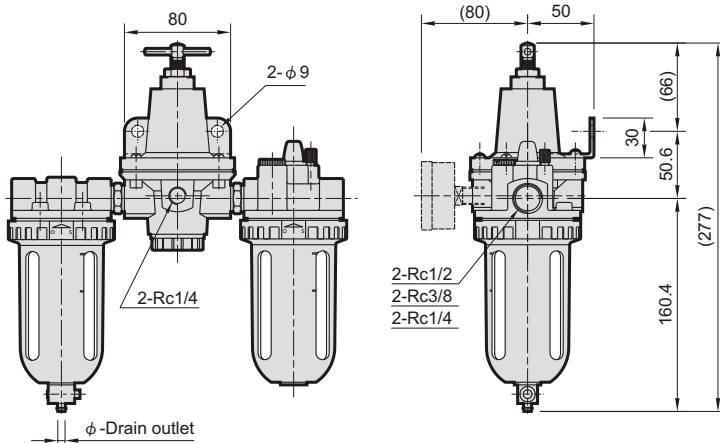
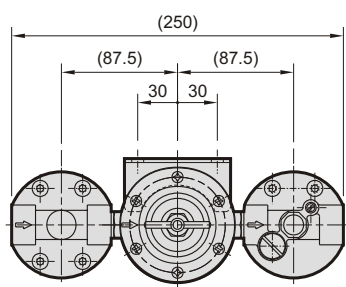

Flow feature

