

MACT402 series

AIR UNITS (F.R.L.UNIT)

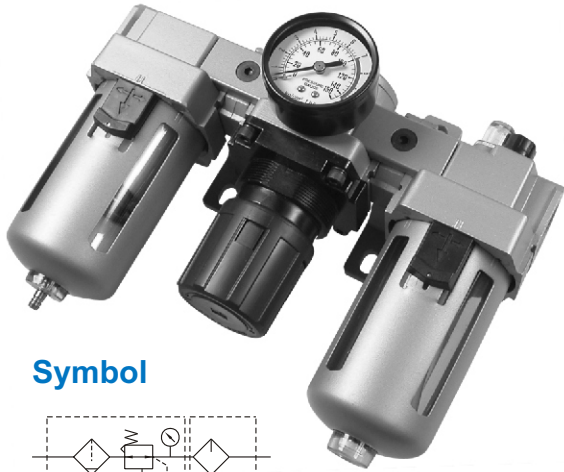

mindman



Symbol

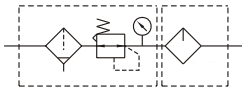

Specification

Model	MACT402		
Components	MAF402, MAR402, MAL402		
Bore No.	10A	15A	20A
Port size	3/8	1/2	3/4
Medium	Air		
Operating pressure range	0.05~1 MPa		
Proof pressure	1.5MPa		
Regulated pressure range	0.05~0.85MPa		
Ambient temperature	-5~+60℃ (No freezing)		
Filter element	Standard: 40 μm Option: 5, 20 μm		
Lubricating oil capacity	180 c.c		
Min. Flow for oil drip	200 l/min		
Recommended lubricating oil	Turbine oil ISO-VG32		
Attachment	Pressure gauge, bracket		
Weight	2392 g		

※ Standard unit contains semi-auto-drain function when operating pressure below 0.05 MPa.

Order example

MACT402 - 20A - D - □ - □

MODEL

BORE SIZE
10A : 3/8
15A : 1/2
20A : 3/4

D: auto drain valve

FILTER ELEMENT
Blank: 40 μm
5u: 5 μm
20u: 20 μm

PORT THREAD
Blank: Rc thread
G: G thread
NPT: NPT thread

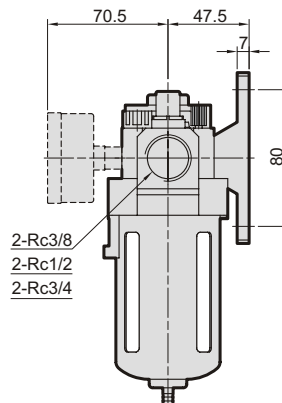
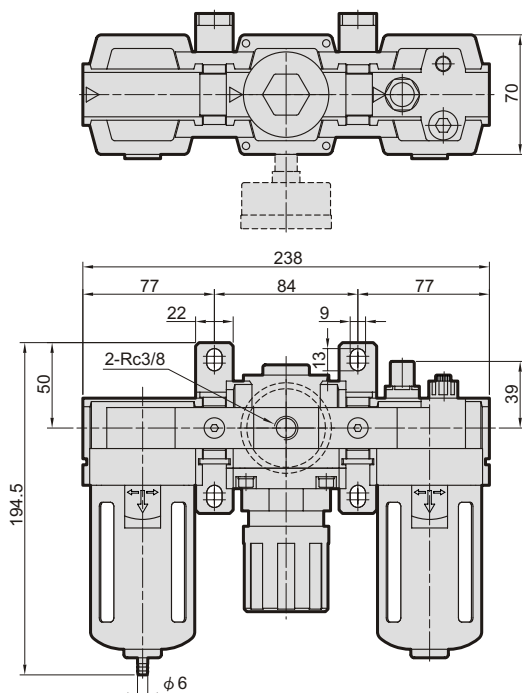

Flow feature

10A, 15A, 20A Primary pressure 0.7 MPa

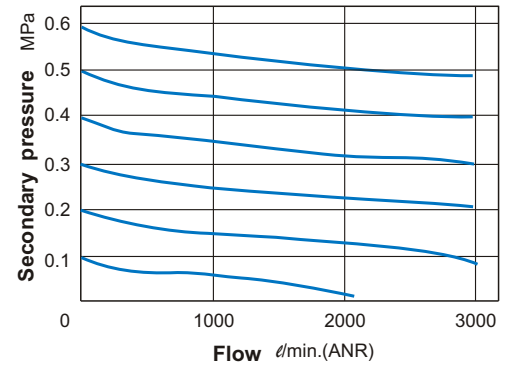

mindman