

MAR100 series

AIR UNITS (R. UNIT)



mindman



Symbol

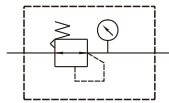

Specification

Model	MAR100
Port size	M5×0.8
Medium	Air
Max. operating pressure	1 MPa
Proof pressure	1.5 MPa
Regulated pressure range	0.05~0.7MPa
Ambient temperature	-5~+60°C (No freezing)
Attachment	Pressure gauge (PG-25), bracket
Weight	100 g

Order example

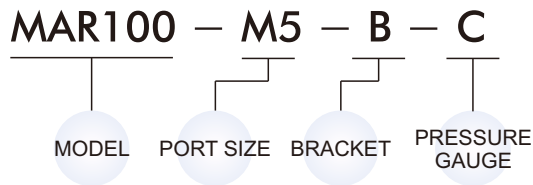

Flow feature

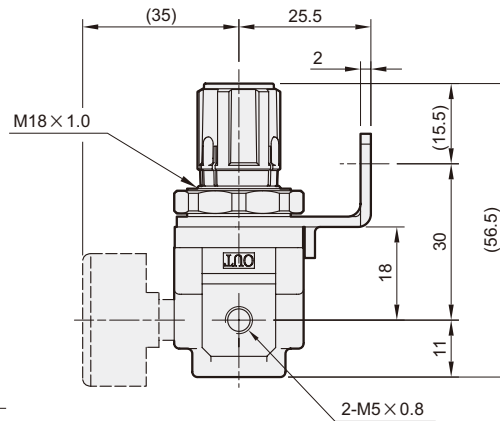
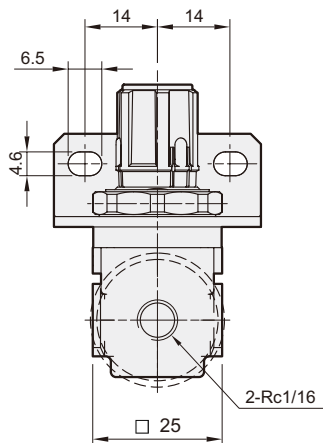
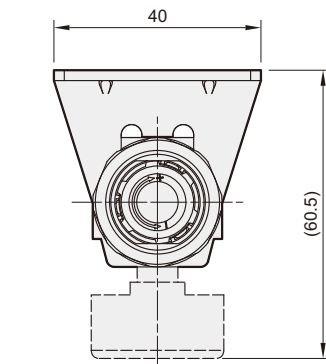
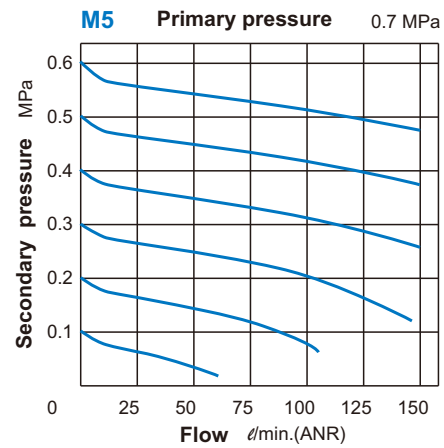

mindman